

# *Sunbeam*®/MD

**WARM MIST HUMIDIFIER**

**HUMIDIFICATEUR À  
VAPEUR TIÈDE**



**Model/Modèle 1128**  
**[www.sunbeam.ca](http://www.sunbeam.ca)**

**READ AND SAVE THESE INSTRUCTIONS**

**LISEZ ET GARDEZ CES INSTRUCTIONS**

**P.N. 119429 Rev. B**

# READ AND SAVE THESE INSTRUCTIONS

**When using electrical appliances, basic safety precautions should always be followed. Failure to follow these safety precautions may result in personal injury or property damage, fire or shock.**

1. Always have water in the water tank when operating unit.
2. Use only clean, distilled or filtered tap water. Using tap water with a high mineral content (hard water) will result in the need for more frequent cleanings.
3. Be sure the filling cap of the tank is firmly tightened.
4. Position the unit within the room so the air output from the top grill is aimed away from children, walls and furniture.
5. When removing the Tank, use one hand on the Tank Handle and lift straight up. DO NOT use if tank is cracked.
6. DO NOT place the appliance near heating devices. Keep the cord away from heated surfaces and areas where it can be stepped on or tripped over.
7. Use only 120V AC outlet. Be sure unit is plugged in firmly and completely. As with any electrical device, plug and unplug unit with dry hands only.
8. Turn the humidifier off and unplug the unit when: not in use, before moving or before cleaning. Please refer to the CARE AND MAINTENANCE section in this manual.
9. To avoid the risk of fire, shock or personal injury, do not use an extension cord.

**WARNING:** Never operate unit with a damaged cord or plug.

10. Always place unit on a flat, level surface AWAY from direct sunlight or computers or other sensitive electronic equipment.
11. This product does not offer a medicine cup feature. DO NOT add medication of any type into the mist director, base or water tank. Do not cover or place anything over any opening. Never drop or insert any object into any openings.
12. The unit should not be left unattended in closed rooms as air could become saturated and leave condensation on walls or furniture. Always leave room door partly open.
13. **DANGER:** To guard against electrical shock, NEVER immerse the humidifier motor unit (base) in water or other liquids.
14. Regular cleaning of the unit is needed. Please refer to the CARE AND MAINTENANCE section in this manual.
15. DO NOT use outdoors.
16. Turn the humidifier OFF if the relative humidity exceeds 60%, or if you notice condensation on the inside of your windows. For proper humidity reading use a hygrometer which is available in many retail stores.
17. Do not place the humidifier directly on wood furniture or other surfaces that can be damaged by water. For best results, place on a level, waterproof surface.
18. The unit contains no consumer serviceable parts. To reduce the risk of electrical shock, do not attempt to open the wiring cover.
19. Do not place unit on top of carpet, towels or flammable objects.
20. Failure to clean device per the cleaning instructions in the instruction book may result in overheating or fire.

## FOR HOUSEHOLD USE ONLY

To reduce the risk of electrical shock, this product has a polarized plug (one blade is wider than the other). As a safety feature, this plug will fit into the outlet only one way. If the plug does not fit fully into the outlet, reverse the plug. If it still does not fit, contact a qualified electrician. Do not attempt to defeat this safety feature.

# CONSUMER SAFETY INFORMATION

## NOTES:

- This is an electrical appliance and requires attention when in use.
- If moisture forms on the walls or windows of the room, turn off the humidifier. The room already has plenty of humidity and additional moisture may cause damage.
- DO NOT block air inlet or outlet.
- Keep unit away from surfaces that can be damaged by water and/or heat (such as wood floors).
- Place mat underneath the unit during use.
- Do not place the humidifier on carpet. The heat sink underneath the humidifier might cause the carpet to be discolored and may cause overheating of the unit.

## PRE-OPERATING INSTRUCTIONS

1. It is recommended that the humidifier base and water tank be cleaned before first use. (See CARE AND MAINTENANCE instructions)
2. Be sure the humidifier is switched OFF (O).
3. Select a location for your humidifier, on a flat level surface about 4 inches away from the wall. DO NOT place the humidifier on a finished floor or near furniture, which can be damaged by too much heat, moisture or water. Place on a moisture resistant surface.
4. Remove the tank from the water tray.
5. Bring the tank to the sink, turn upside down and twist off the tank cap by turning counter clockwise. Fill tank with cool tap water. DO NOT fill with warm water as this may cause leaking. Replace the cap on tank FIRMLY.
6. Make sure the safety lock is rotated completely to the locked position. Place tank back on to the water tray. The tank will immediately begin to empty into the tray.
7. Plug power cord into a 120V AC wall outlet only

## OPERATING INSTRUCTIONS

1. To turn the humidifier on, switch the knob to the desired position. High (II) will produce the maximum moisture and Low (I) will produce the longest run time and quieter performance. The power light will be on. It is normal for the humidifier to take 10 minutes to boil the water and begin to mist.
2. To turn the unit OFF, switch the knob to Off (O).

## RESET PROCEDURE

**NOTE:** When the water in the tank is empty and the water in the heating chamber is almost empty, the Automatic Shut Off will activate. The RESET light (  ) will illuminate and the humidifier will not operate again until you refill the water tank and reset the humidifier as outlined below.

**WARNING:** Steam, heating element and base of humidifier may be extremely hot and could cause burns. Turn humidifier off and allow to cool for 60 minutes before opening or moving. Do not set down on carpet or any other surface which may get damaged by heat.

1. Be sure the humidifier is switched off (O).
2. Unplug the unit.
3. Remove and refill the water tank, being sure to follow the Daily Maintenance instructions. Replace the tank onto the water tray.
4. Allow 15 minutes for the Automatic Shut Off to reset.
5. After the 15 minutes, plug the unit back into the outlet and turn the Power knob to High (II). The Reset light should now be off (if not, repeat steps 1-5). In about 10 minutes the unit will begin to produce moisture.

**IMPORTANT:** If you do not plan to use the humidifier for two or more days, make sure any residual water is drained from the water tank and water tray to prevent algae or bacterial growth.

**DANGER:** Improper use of electric cords and plugs can cause a burn, fire or other electric shock hazard. Never “yank” on cord to remove from outlet, grip plug and pull from outlet. Check the power cord and plug for damage. A damaged cord or plug must be repaired before using the humidifier.

## CARE AND MAINTENANCE

The following maintenance procedures must be routinely followed in order to ensure proper, efficient operation of your humidifier. The unit WILL NOT WORK CORRECTLY if it is not cleaned properly.

**DAILY MAINTENANCE** *Allow the humidifier to cool before maintenance.*

1. Before cleaning, set the control to OFF(O) position and unplug the unit from the electrical outlet.
2. Remove the water tank then unlock the misting chamber by rotating the safety lock towards the front of the unit (Figure 1).  
Lift unit to remove from water tray.
3. Empty water and minerals from the water tray and place in the top rack of the dishwasher. This will remove any sediment and dirt that has accumulated in the water tray.
4. Replace misting chamber and engage safety lock. Wipe the heating element clean with a soft cloth after it has had a chance to cool.
5. The heating element is lined with a coating that is designed to provide the easiest cleaning and prolong the operating efficiency of the humidifier.



**Figure 1**

DO NOT use any metal or hard objects to clean the Heating Element. Never use detergents, gasoline, kerosene, glass cleaner, furniture polish, paint thinner or other household solvents to clean any part of the humidifier.

**WEEKLY MAINTENANCE** *Allow the humidifier to cool before maintenance.*

1. Repeat steps 1-4 in the Daily Maintenance section.
2. Clean the water tray by partially filling the tray with one 8-oz. cup of undiluted white vinegar. Let solution stand 20 minutes, cleaning all interior surfaces with a soft brush. Dampen a cloth with undiluted white vinegar and wipe out entire water tray to remove scale.

### **Disinfect tank:**

1. Fill tank with 1/2 teaspoon of chlorine bleach and 1/2 gallon of water.
2. Let the solution stand for 20 minutes, swishing every few minutes. Wet all surfaces.
3. Carefully empty the tank after 20 minutes, and rinse with warm water until you cannot detect any bleach odor. Dry with a clean cloth or paper towel.
4. Refill the water tank with cool tap water. Replace the housing and lock it to the base. Insert the water tank. Follow PRE-OPERATING and OPERATING INSTRUCTIONS.

Figure 2:

- A. Humidifier Tank
- B. Humidifier Housing
- C. Tank Handle
- D. Control Knob
- E. Humidifier Base
- F. Safety Lock
- G. Heating Element

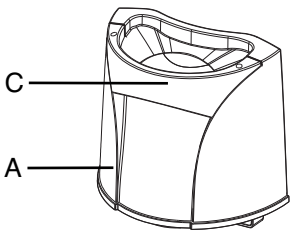

- A. Réservoir de 'humidificateur
- B. Boîtier de l'humidificateur
- C. Poignée du réservoir
- D. Bouton de contrôle
- E. Base de l'humidificateur
- F. Serrure de sécurité
- G. L'élément chauffant

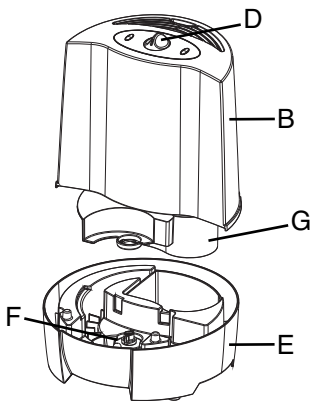

### 3 Years Limited Warranty

Sunbeam Products, Inc. doing business as Jarden Consumer Solutions or if in Canada, Sunbeam Corporation (Canada) Limited doing business as Jarden Consumer Solutions (collectively "JCS") warrants that for a period of three years from the date of purchase, this product will be free from defects in material and workmanship. JCS, at its option, will repair or replace this product or any component of the product found to be defective during the warranty period. Replacement will be made with a new or remanufactured product or component. If the product is no longer available, replacement may be made with a similar product of equal or greater value. This is your exclusive warranty. Do NOT attempt to repair or adjust any electrical or mechanical functions on this product. Doing so will void this warranty.

This warranty is valid for the original retail purchaser from the date of initial retail purchase and is not transferable. Keep the original sales receipt. Proof of purchase is required to obtain warranty performance. JCS dealers, service centers, or retail stores selling JCS products do not have the right to alter, modify or any way change the terms and conditions of this warranty.

This warranty does not cover normal wear of parts or damage resulting from any of the following: negligent use or misuse of the product, use on improper voltage or current, use contrary to the operating instructions, disassembly, repair or alteration by anyone other than JCS or an authorized JCS service center. Further, the warranty does not cover: Acts of God, such as fire, flood, hurricanes and tornadoes.

#### **What are the limits on JCS's Liability?**

JCS shall not be liable for any incidental or consequential damages caused by the breach of any express, implied or statutory warranty or condition.

Except to the extent prohibited by applicable law, any implied warranty or condition of merchantability or fitness for a particular purpose is limited in duration to the duration of the above warranty.

JCS disclaims all other warranties, conditions or representations, express, implied, statutory or otherwise.

JCS shall not be liable for any damages of any kind resulting from the purchase, use or misuse of, or inability to use the product including incidental, special, consequential or similar damages or loss of profits, or for any breach of contract, fundamental or otherwise, or for any claim brought against purchaser by any other party.

Some provinces, states or jurisdictions do not allow the exclusion or limitation of incidental or consequential damages or limitations on how long an implied warranty lasts, so the above limitations or exclusion may not apply to you.

This warranty gives you specific legal rights, and you may also have other rights that vary from province to province, state to state or jurisdiction to jurisdiction.

#### **How to Obtain Warranty Service**

##### **In the U.S.A.**

If you have any question regarding this warranty or would like to obtain warranty service, please call 1-888-264-9669 and a convenient service center address will be provided to you.

##### **In Canada**

If you have any question regarding this warranty or would like to obtain warranty service, please call 1-888-264-9669 and a convenient service center address will be provided to you.

In the U.S.A., this warranty is offered by Sunbeam Products, Inc. doing business Jarden Consumer Solutions located in Boca Raton, Florida 33431. In Canada, this warranty is offered by Sunbeam Corporation (Canada) Limited doing business as Jarden Consumer Solutions, located at 20 B Hereford Street, Brampton, Ontario L6Y 0M1. If you have any other problem or claim in connection with this product, please write our Consumer Service Department. **PLEASE DO NOT RETURN THIS PRODUCT TO ANY OF THESE ADDRESSES OR TO THE PLACE OF PURCHASE.**

©2013 Sunbeam Products, Inc., doing business as Jarden Consumer Solutions. All rights reserved. In Canada, imported and distributed by Sunbeam Corporation (Canada) Limited doing business as Jarden Consumer Solutions, 20 B Hereford Street, Brampton, ON L6Y 0M1.